

The logo for Earth EV, featuring the word "EARTH" in a large, white, sans-serif font above the word "EV" in a smaller, white, sans-serif font. A registered trademark symbol (®) is located to the right of "EV". A small blue dot is positioned above the letter "A" in "EARTH".

EARTH
EV®



Earth EV

7kW and 22kW AC Chargers

Technical Specifications

Installation and Operation Manual



Introduction

Welcome to the Earth EV family!

We extend our gratitude for choosing our AC Charging Point and for supporting Australian business. Your safety and satisfaction are our utmost priorities. Therefore, we urge you to thoroughly review this manual to ensure proper understanding of the device's operation before going ahead with installation, maintenance, or operation.

It is imperative to adhere to the safety instructions outlined in this manual to mitigate any potential risks of injury, damage to the device, or other hazards. Earth EV cannot assume responsibility for claims arising from failure to follow these safety measures.

This manual serves as a comprehensive guide for the installation, utilisation, and maintenance of the AC Charging Point. Installation procedures should exclusively be undertaken by qualified Electricians. While the text and illustrations within this manual offer general explanations of Earth EV's chargers and associated equipment, please be aware that actual products may differ slightly from the descriptions provided herein.

The Earth EV mobile app is a professional-grade electric vehicle charging management application available for iOS and Android devices. It serves as the primary interface for users to interact with their Earth EV chargers and manage their charging activities.

Safety

- **Installation and Wiring by Qualified Installer:** Installation and wiring of the EV charger should only be performed by personnel with professional qualifications in electrical work. Failure to do so may result in hazardous electric shock due to improper installation.
- **Ensure Disconnection of Mains Power:** Before starting any wiring procedures, ensure that all mains input power supplies are completely disconnected. Failure to do so may result in hazardous electric shock during the installation process.
- **Avoid Metal Objects Inside the Charging Point:** It is crucial to refrain from leaving any metal objects such as bolts or gaskets inside the EV Charging point. Doing so may lead to hazardous blasts and fires due to potential short circuits or electrical malfunctions.
- **Keep Flammable or Explosive Substances Away:** It is imperative to ensure that no flammable or explosive substances are kept near the EV Charging point. Failure to adhere to this precaution may result in hazardous blasts due to the ignition of these substances.
- **Secure Grounding of Earth Terminal:** The earth terminal of the EV Charging point must be securely grounded to prevent hazardous electric shock incidents. Proper grounding ensures the safe operation of the charging equipment.
- **Secure Attachment of Charging Tether:** The charging point's tether must be securely attached to prevent any risk of damaging the equipment during charging operations. Loose or improperly attached tethers can lead to equipment malfunction or damage.
- **Prohibition for Minors or Persons of Restricted Ability:** It is strictly forbidden for minors or persons with restricted abilities to use the charging point to prevent accidents or injuries. Only individuals with the necessary knowledge and capabilities should handle the charging equipment.



Safety

- **Avoid Forced Charging in Case of Failure:** Forced charging is strictly prohibited in the event of electric vehicle or charging point failures. Attempting to force a charge under such circumstances may result in further damage to the equipment or pose safety risks.
- **Check for Defective Charging Equipment:** It is prohibited to use the charging point if the charging adapter or charging cables are defective, cracked, worn, broken, or if the charging cables are exposed. In case of any such abnormalities, contact Earth EV promptly for assistance.
- **Ensure Safe Charging Conditions:** Electric vehicles can only be charged when it is safe to do so, with the engine off and the vehicle stationary. Charging under unsafe conditions may pose risks to both the vehicle and the charging equipment.
- **Qualified Personnel for Accessory Replacement:** Any accessory replacement or maintenance tasks must be conducted by qualified personnel. Prohibiting the presence of any foreign matter, specifically metals, in the controller is crucial to avoid hazardous blasts and fires resulting from potential electrical malfunctions.
- Adhering to these safety precautions is essential to ensure the safe and efficient operation of the Earth EV charger while minimizing the risks of accidents or injuries.
- A routine safety inspection to the point infrastructure is to be conducted at the start of every charge. Keeping the charging connector clean and dry, wipe with a clean and dry cloth whenever required.



1. Product Overview

1.1 Product Introduction

The Earth EV smart AC charge point is an AC charging point that you use to supply electricity to your electric vehicle. The Earth EV charger offers tailor-made, intelligent and network charging solution for home and business. The charger can connect to the internet via Wi-Fi or LAN with 4G available upon request as an option. All the Earth EV's AC products share the same wallbox shell and appearance. The model number definitions of the charging points follow the rules as shown below.

Part Number	Power	Phase	Current	Socket	Cable	LED
7KWLEDS	7kW	1	32A	YES		YES
7KWLEDT	7kW	1	32A		YES	YES
22KWLEDS	22kW	3	32A	YES		YES
22KWLEDT	22kW	3	32A		YES	YES

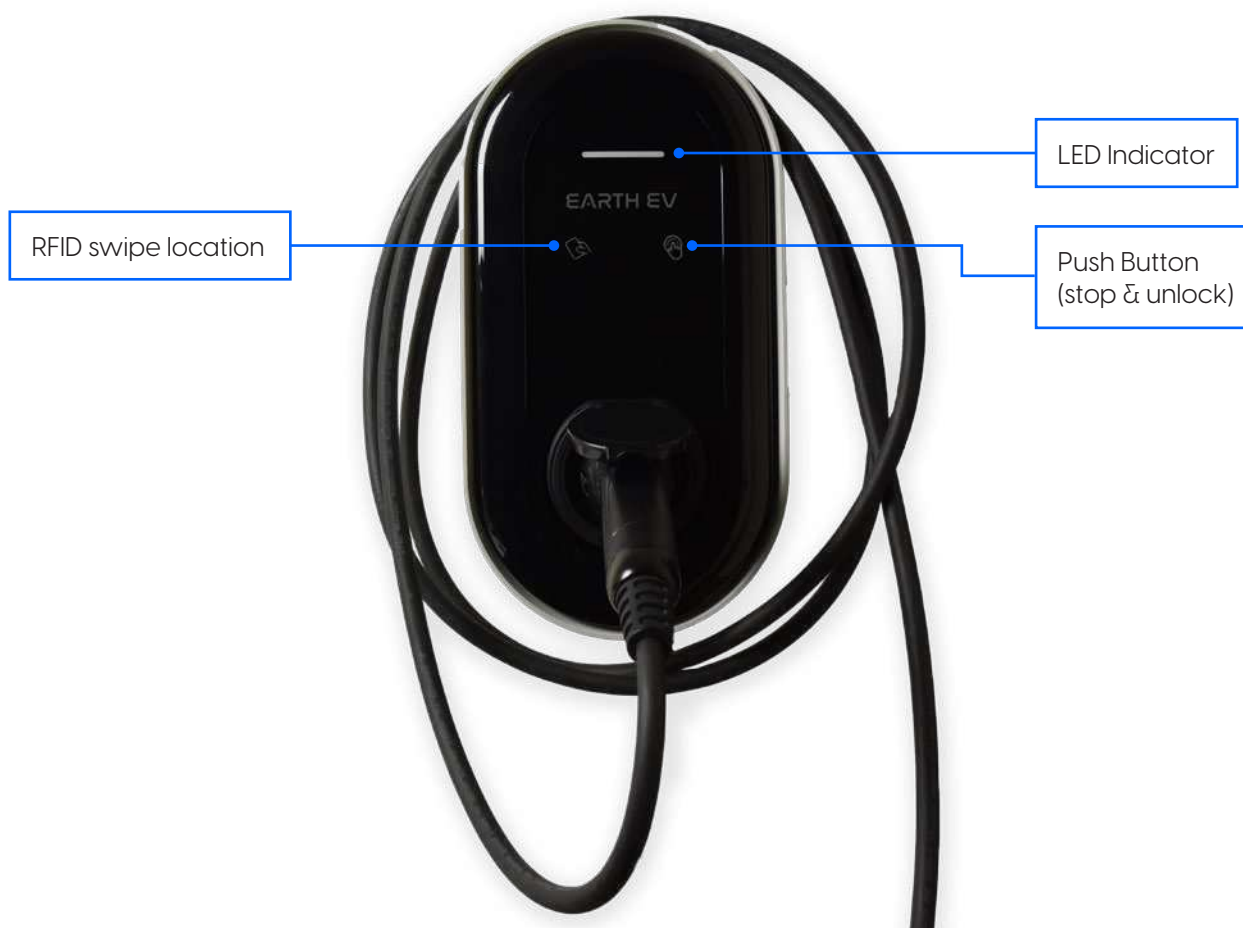



1. Product Overview

1.2 Product components

Name	Function
Plastic casing	Protective, lightweight (custom design), UV resistant and will not change colour
RFID area identification	RFID swipe card to start charging icon located on front plate
Touch button	Start, stop, located on front plate
Round light bar	Charging instructions
LED Light Strip	Status indication (Green, Blue, Yellow & Red), refer section 4.3
Tether	Charger cable (TPU)
Current Transformers (CT)	1 x single phase 3 x 3phase
L1 /N/PE incoming line	Power incoming line

1.3 Features

Exterior

Soft and uniform customized icon for 3 colour charger status indication

Environmental protection plastic shell IK10

Small and compact size: 340 x 200 x 136 approximately

The charger is IP55 waterproof and dustproof is IP54 rated which is governed by the actual socket IP rating)

Circuit Breaker 40A needed externally – see below re RCBO

Fixing bracket to have security screws and fixing tool provided

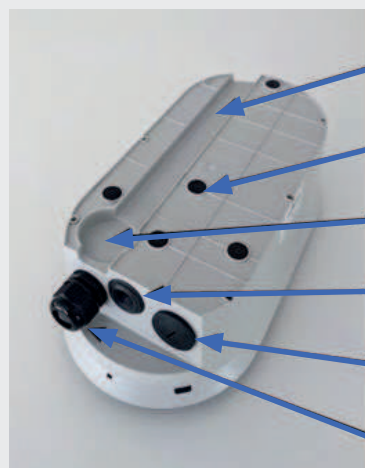

Rear Wiring Channel

Waterproof Drill Points

Rear Wiring Hole

Spare Blanking Plate

Bottom Wiring Hole (Operational on Socket Version)

Waterproof Reducing Connector Gland



1. Product Overview







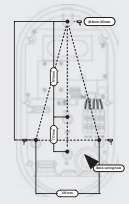

1.4 Technical Specifications

Description	Valve	
AC POWER	7kW	1Ø + N + PE
	22kW	3Ø + N + PE
RATED VOLTAGE	7kW	230V AC, 50/60Hz
	22kW	400V AC, 50/60Hz
RATED CURRENT	7kW & 22kW	32A
TETHERED VERSION	388.45mm (h) x 202.45mm (w) x 107.26mm (d) 7kW 4kg & 22kW 5kG 5meter Type 2 tether length	
SOCKET VERSION	388.45mm (h) x 202.45mm (w) x 116mm (d) 7kW 2.4kg & 22kW 2.6kG Type 2 socket	
PACKAGING	Tethered 455mm (h) x 260mm (w) x 230mm (d) Socket 455mm (h) x 260mm (w) x 150mm (d)	
APPLICABLE STANDARDS	IEC61851, IEC62196, IEC62955	
CHARGING CONTROL	App (Earth EV default) RFID access & Plug & Charge	
DISPLAY/INDICATION	4 colour LED	
DISPLAY/INDICATION	3 colour LED	
COMMUNICATION	OCPP 1.6J Wi-Fi /Bluetooth/LAN are standard (4G Optional)	
SAFETY PROTECTION	TypeA (30mA) + DC 6mA built-in, over current protection, over voltage protection, under voltage protection, over temperature protection, leakage protection, etc.	
ENVIRONMENTAL	- IP55	
	- Operating temperature: -30°C ~ 50°C (Storage -40°C ~ 75°C)	
	- 95%RH, No water droplet condensation	
	- Altitude >2000m	
Wi-Fi	- Signal: 2.402GHz - 2.483Ghz	
	- Modulation: 802.11 b/g/n	
	- Maximum Transmitter Power: 11b: 19dBm; 11g: 16dBm; 11n: 15dBm	
	- Antenna gain: 2.0dBi	
	- Antenna configuration: 1Tx1R	
BLUETOOTH	- Signal: 2.400-2.4835GHz	
	- Modulation: GFSK	
	- Maximum Transmitter Power: 10dBm	
	- Antenna gain: 2.0dBi	
	- Antenna configuration: 1Tx1R	



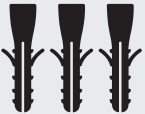







2. Installation

2.1 Equipment Supplied

Earth-EV Charger	Drill Cut Out	RFID Cards	CT Clamps Quick Install (1 x Single & 3 x 3-phase)	Quick Install Guide
				
Wall anchors (8 x 40 mm)	Insulated Ring Terminals	Screws (Ø5 x 40 mm)	Waterproof gaskets	
				

2.2 Recommended Tools

Tape Measure	Drill (for relevant material) & Ø8mm drill bit	Hammer	Screwdrivers (Phillips and Flathead) Preferable to have an electric screwdriver
			
Wire Stripper and crimper	Utility knife	Step drill bits (29mm & 35mm)	Mobile phone or computer with Bluetooth connection for configuration APP setup
			



2. Installation

2.3 Installation steps

PLEASE KEEP PROTECTION PLASTIC FILM ON UNTIL HANDOVER

Step 1

Cut the drilling template from the carton, place tile drilling template on the wall, drill holes where the three fixing points are, insert the wall plugs into the fixing holes.

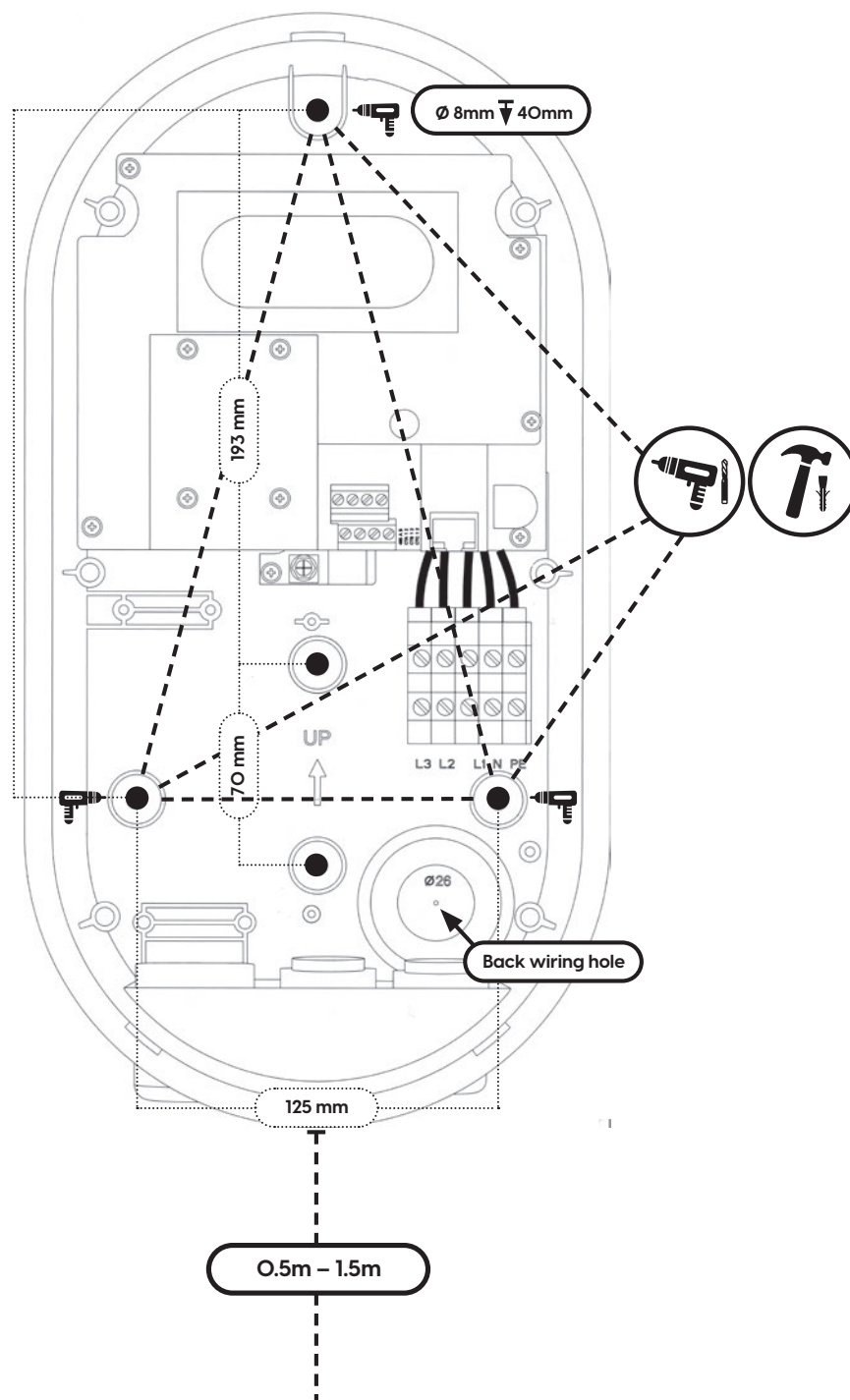



2. Installation

2.3 Installation steps

PLEASE KEEP PROTECTION PLASTIC FILM ON UNTIL HANDOVER

Step 2

Location of drill points for pole-mounted applications

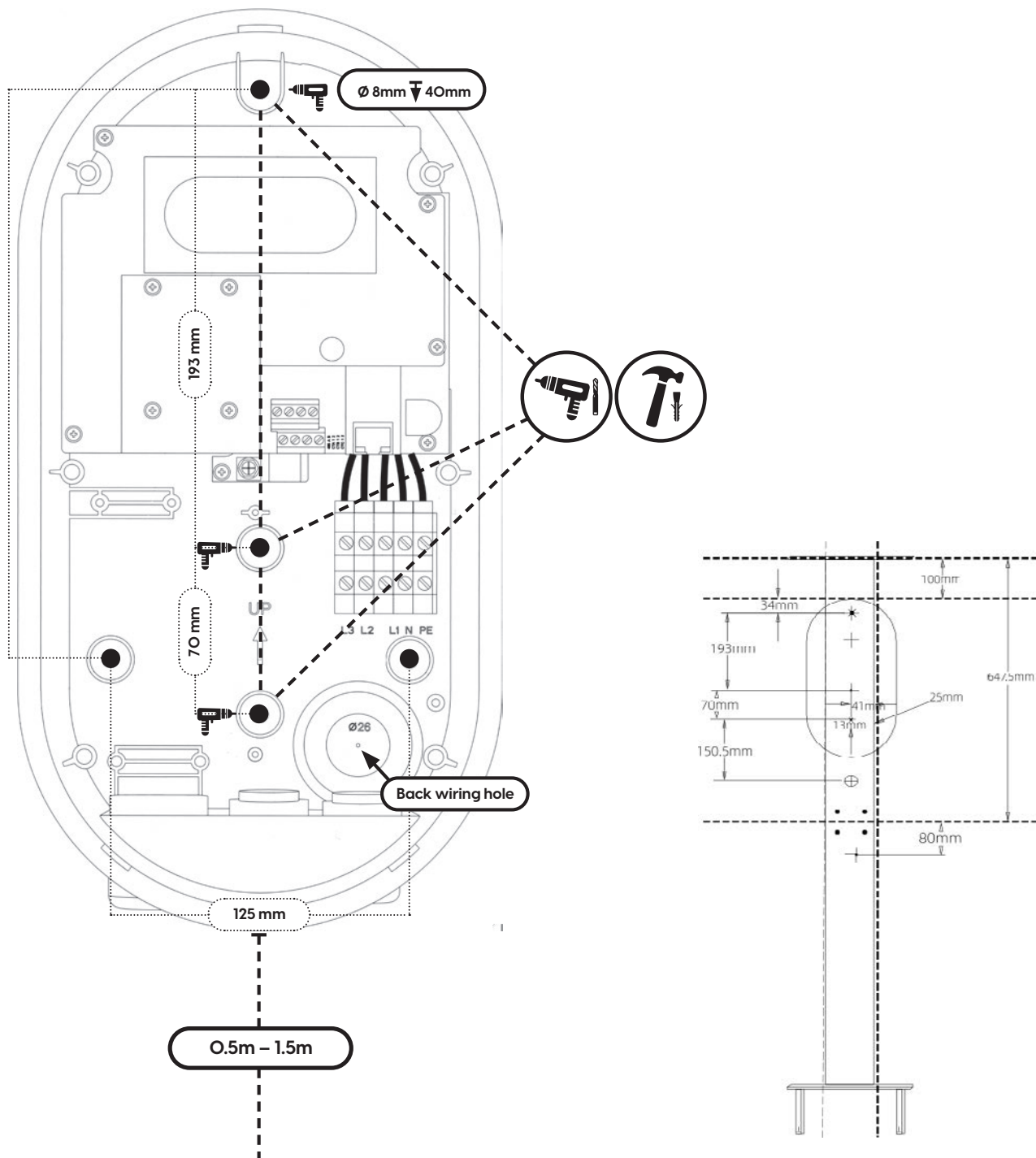



2. Installation

2.3 Installation steps

Step 3

Press the two barbs under the machine and remove the upper cover.

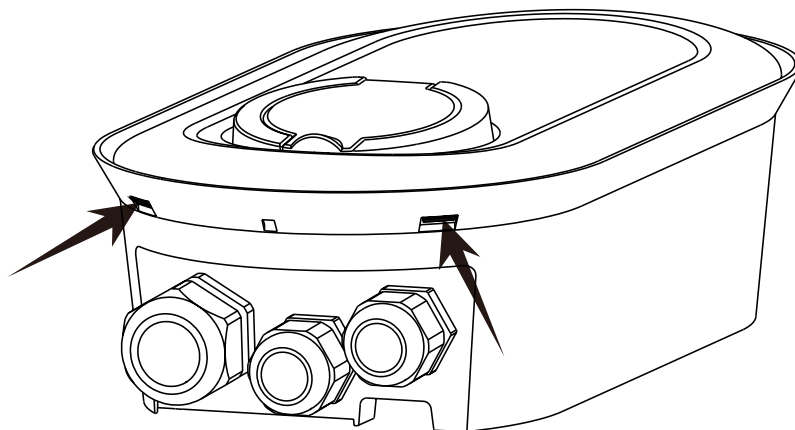

Loosen the six screws of the cover and carefully take out the cover

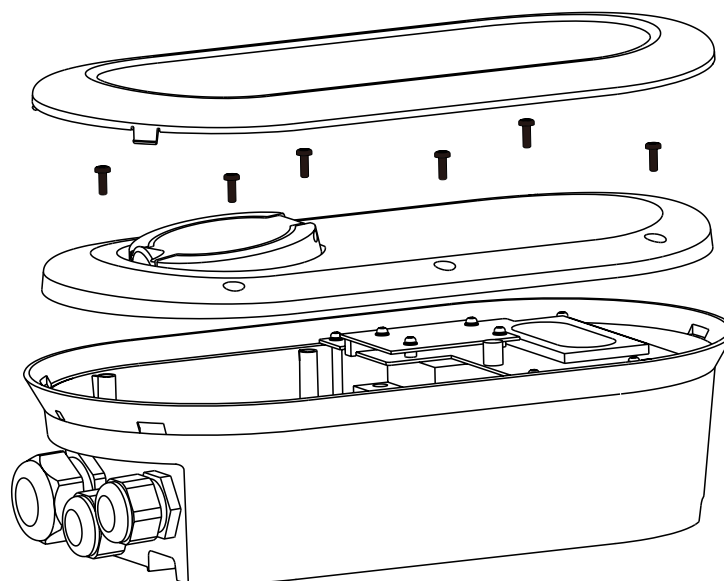



2. Installation

2.3 Installation steps

Step 4

Fix the device on the wall by inserting the screws and waterproof gaskets. Please ensure that these drill holes and waterproof gaskets are used to maintain the chargers IP55 rating.

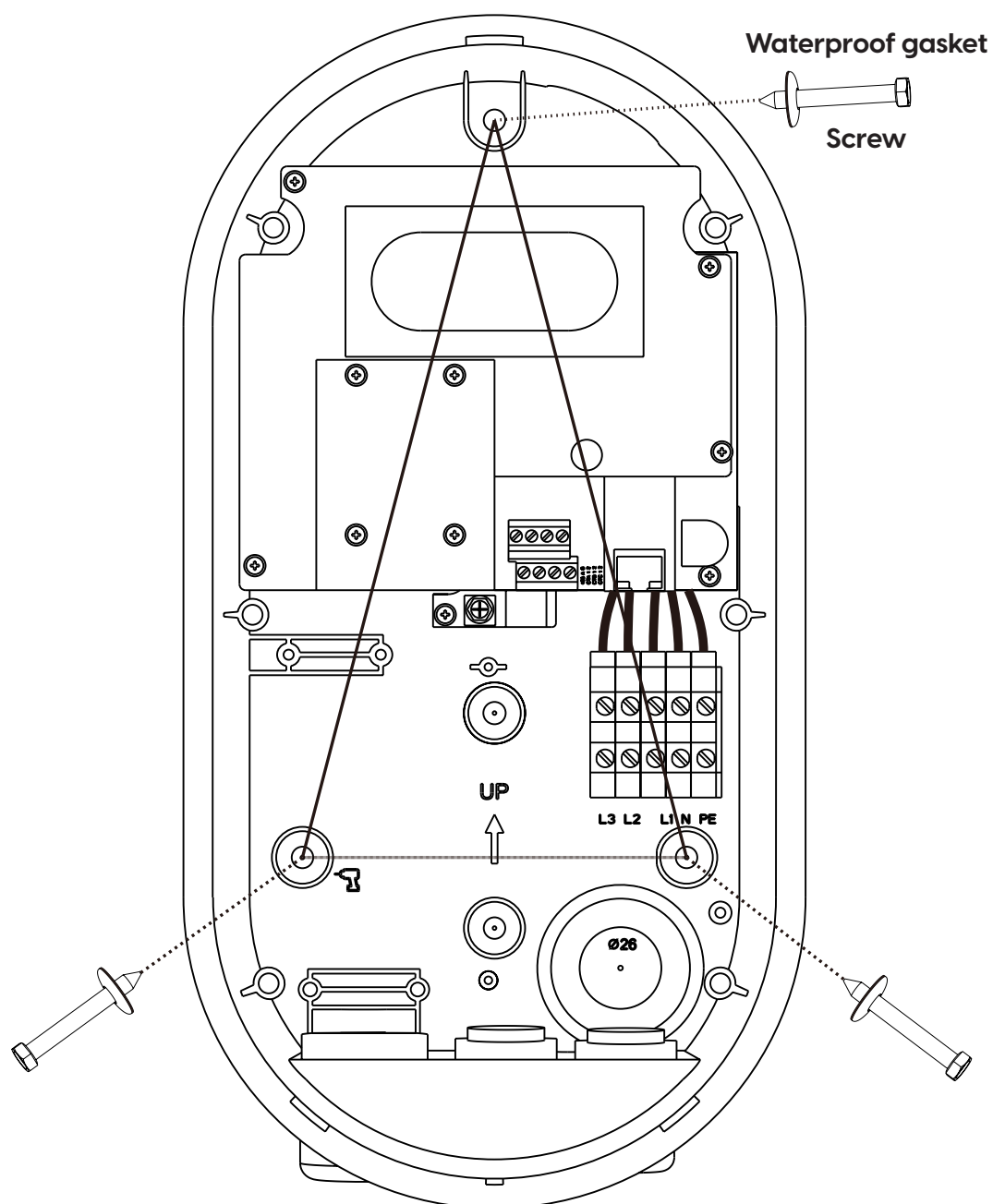



2. Installation

2.3 Installation steps

Step 5 Wiring Diagram, Electrical Wiring

1 and 5 are connected to 485

2 and 6 are connected to the CT on L1

3 and 7 are connected to the CT on L2

4 and 8 are connected to the CT on L3

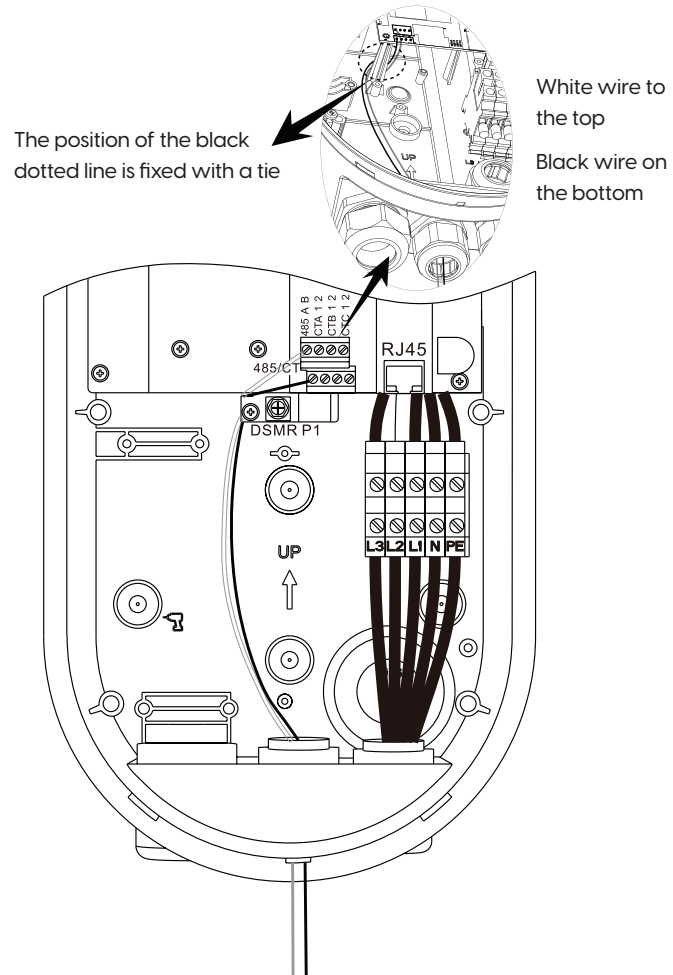

Replace the cover screws replace the upper cover.

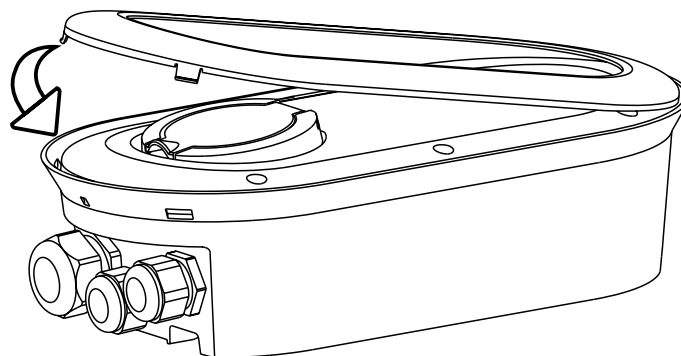



2. Installation

2.5 Smart Home Load Management & Solar Integration

Single Phase

The CT clamp is connected to CTA, the black wire is connected to 1, and the white wire is connected to 2. The CT clamp is connected to the main incoming line of the home power grid. The incoming line phase of the CT clamp is the same as the phase of the power supply line of the charge point.

Three-phase

The three CT clamps are connected to CTA, CTB, and CTC respectively, the black wire is connected to 1, the white wire is connected to 2, the CT clamps are hung at the main incoming line of the home grid, CTA is connected to L1, CTB is connected to L2, and CTC is connected to L3.

IMPORTANT

The direction of the CT clamp arrow is the incoming line direction of the home grid and if the connection cable is >5m the use of pink CAT6 cable is recommended or a power meter. Only put one CT per phase.

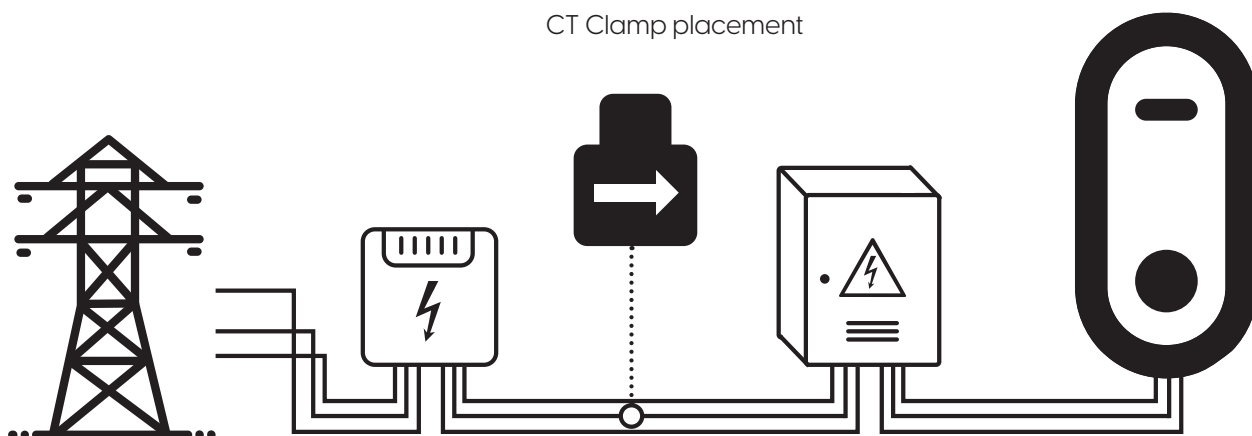



3. Earth EV App



This is the customer app which controls the numerous daily usage functionality of the charger. Please download the Earth EV App using the QR codes below. The Earth EV charger comes with the app free of charge for residential users and is preprogrammed. Once commercial use is activated via the Earth EV app charges will apply.

The Earth EV app can be downloaded by scanning this QR code





3. Earth EV App

3.1 Introduction

The Earth EV ecosystem is a comprehensive solution designed to empower electric vehicle (EV) owners and optimise their charging experience. This document provides an in-depth overview of the Earth EV mobile application, server infrastructure, and the overall system capabilities.

The Earth EV mobile application, developed using the Flutter framework, offers a range of features to enhance the EV charging experience. Key functionalities include:

- **Charger Management:** Users can add, remove, and manage their EV chargers with ease. The app provides comprehensive charger information, including type and power output specifications, and allows for real-time monitoring of charging status and power output.
- **User Profile Management:** The app supports user profile creation and management, enabling users to customise their charging preferences and view their charging history.
- **Real-time Monitoring:** Users can monitor the status and performance of their chargers in real-time.
- **Smart Scheduling:** The app includes smart scheduling features that allow users to set charging schedules to optimise energy usage and reduce costs.
- **Bluetooth Connectivity:** The app supports Bluetooth connectivity for local configuration of chargers, providing a seamless user experience.
- **Cloud Integration:** The app integrates with cloud services for data synchronisation and remote management, providing users with access to their charging data from anywhere.

The Earth EV app is designed to provide a robust, user-centric, and efficient solution for managing electric vehicle charging, enhancing the overall EV ownership experience.



3. Earth EV App

3.2 General Usage

Getting Started

1. Download the Earth EV app from the Google Play Store (Android) or App Store (Apple).
2. Open the app and create an account using your email address or Google account.
3. Complete your user profile.
4. Familiarise yourself with the app's interface by exploring the home screen, menu options, and settings.

Adding a Charger

1. From the app's home screen, tap the 'Add Charger' button.
2. Enter the charger's serial number manually or scan the serial number on the charger using your phone's camera.
3. The charger must be visible via Bluetooth for the connection to succeed.
4. Once added, the charger will appear in your list of available chargers with its status and location.
5. Optionally, you can name the charger for easier identification (e.g., 'Home Charger', 'Office Charger').
6. Go to settings icon (top right), Connect to Bluetooth and set the Wi-Fi
7. Exit the Bluetooth section, the charger will beep once indicating that the changes have been implemented.

The Earth EV charger typically comes preprogrammed for Plug & Charge, however, this can easily be changed in the individual chargers management to APP or RFID.

To enable all the Earth EV App's functionality, go to bluetooth connection and select charging mode from Plug and Charge to APP

Starting a Charge Session in APP mode

1. Select the desired charger from your list of available chargers.
2. Ensure your vehicle is properly plugged into the charger.
3. Make sure the charger is in APP mode
4. Tap the 'Start Charging' button in the app.
5. Monitor the charging progress in real-time through the app, which displays the charging speed.
6. The session will automatically end when the battery is full, or you can manually stop it at any time by tapping the 'Stop Charging' button in the APP or Stop and Unlock on the Earth EV charger.
7. After the session ends, you can view a summary of the charging session, including total energy delivered and cost.

Setting a Charger Schedule

1. From the charger details screen, tap 'Set Schedule'.
2. Choose whether this schedule applies every day or to specific days of the week.
3. Choose your start and stop time.
4. Specify the desired charging rate (kW).
5. Confirm the schedule by pressing 'save'.
6. You can view, modify and create additional schedules for your charger from the 'Charger Schedules' section in the app.



3. Earth EV App

Utilising Solar Mode Settings

1. To use 100% solar, turn the Solar Mode toggle to on and ensure the solar and grid power selector is on zero amps / kW.
2. To use the maximum amount of solar and control the amount of grid energy used, simply set the desired amount of grid power in the solar and grid section of solar mode.

Viewing Charging History Report

1. Navigate to any 'Charger Information' section in the app.
2. Select the 'Charging History' report (calendar icon).
3. Choose the time period for the report (e.g., daily, weekly, monthly).
4. Use the in-app tools to view the data directly within the application.

Managing User Profiles

1. Navigate to the 'Profile' section in the app.
2. Update your personal information such as name, contact details, and payment methods.
3. Add or remove vehicles from your profile.

Add a shared User.

1. If you'd like to share your charger, get the potential user to download the Earth EV app and set up the charger. Once added go to Charger Settings, Shared Access and select Add Shared User. Enter the code that they have received and now they have access to your Earth EV Charger.

Accessing Help and Support

1. Navigate to the 'Help' section in the app.
2. Browse through the FAQs to find answers to common questions.
3. Contact customer support via email or phone for assistance.
4. Access user guides and tutorials to better understand the app's features.



3. Earth EV App

3.3 Overview

Key Features

- User-friendly interface with intuitive navigation
- Real-time charger status monitoring
- Charging session scheduling and management
- Energy consumption tracking and reporting
- User profile and preferences management
- Bluetooth connectivity for local charger control
- Integration with cloud services for data synchronisation and remote management
- OCR-based charger serial number scanning

Technical Specifications

- Developed using Flutter framework for cross-platform compatibility
- Utilises Bluetooth Low Energy (BLE) for local communication with chargers
- Implements secure authentication
- Integrates with cloud services for data synchronisation and remote management
- Uses backend services including authentication, storage, and API
- Supports real-time data updates and GraphQL queries



3. Earth EV App

3.4 Detailed Functionality

- **User Authentication:** The app uses Cognito for secure user authentication, ensuring that user data is protected and accessible only to authorised users.
- **Charger Management:** Users can add, remove, and manage their EV chargers. The app provides comprehensive charger information, including type and power output specifications, and allows real-time monitoring of power output.

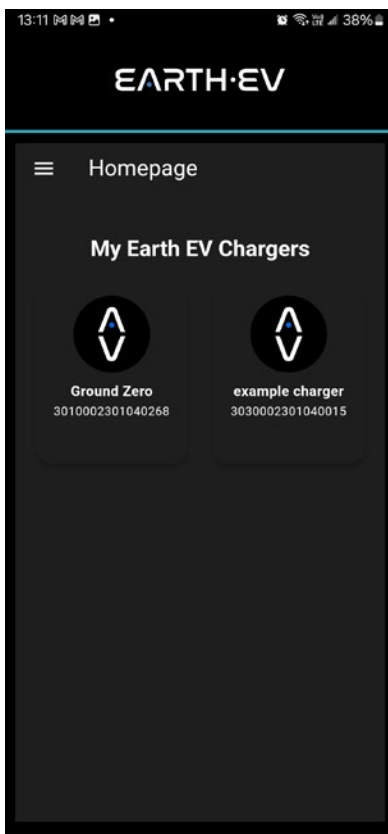

Earth EV App Home Screen

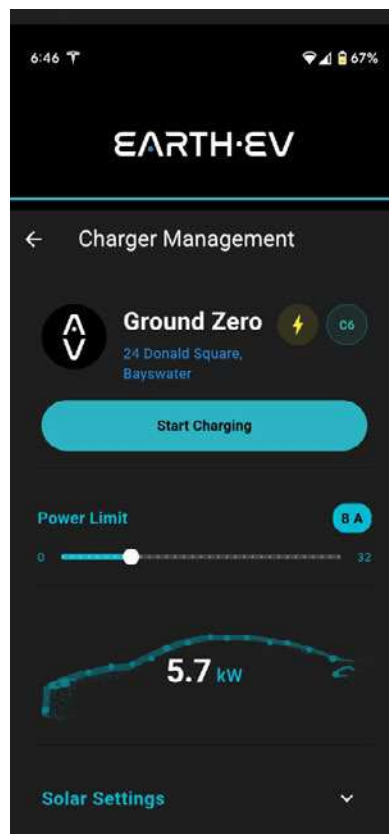

Charger Management Interface 1

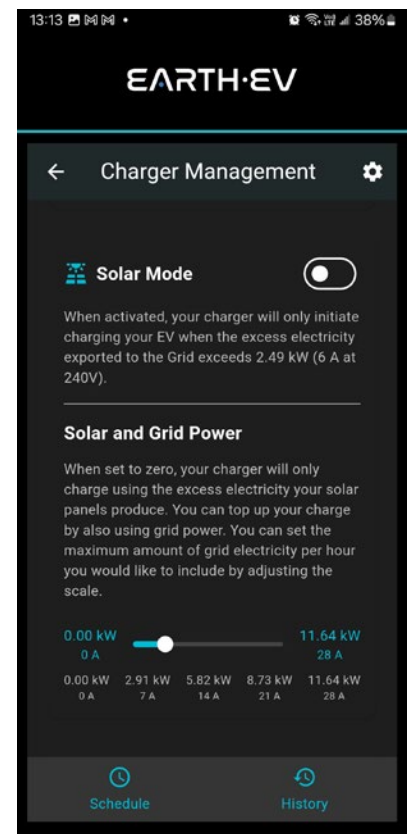

Charger Management Interface 2

Real-time Monitoring

The app offers real-time monitoring of charger status, providing users with up-to-date information on their charging sessions and energy consumption.

Scheduling and Management

Users can create charging profiles that define schedules which specify times in which the charge point should charge and how much current should be supplied.



3. Earth EV App

Energy Consumption Tracking

The app tracks energy consumption and provides detailed reports, helping users understand their energy usage patterns and make informed decisions.

Bluetooth Connectivity

The app uses Bluetooth Low Energy (BLE) for local communication with chargers, allowing users to control and configure their chargers even without an internet connection.

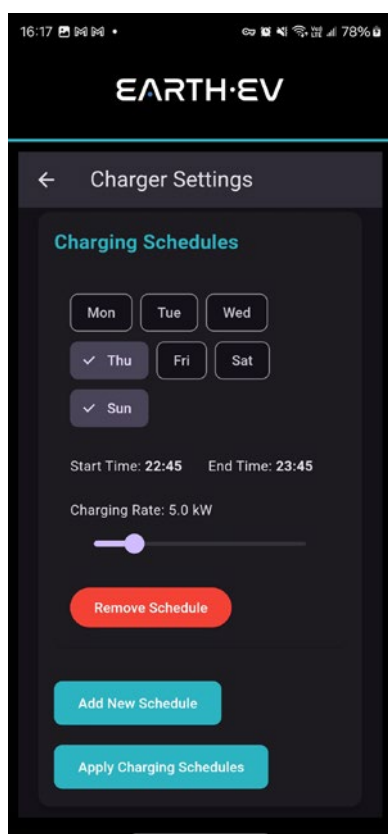

Charger Settings and User Preferences

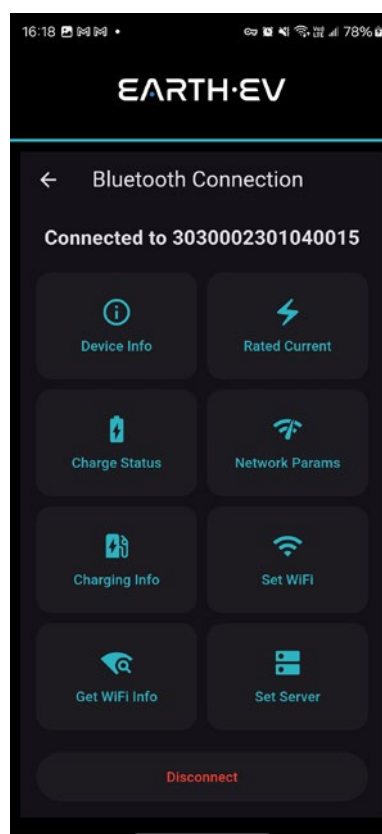

Bluetooth Charger Connection Interface

OCR-based Serial Number Scanning

The app includes an OCR (Optical Character Recognition) feature for scanning charger serial numbers, simplifying the process of adding new chargers.



3. Earth EV App

Transition matrix and associated descriptions:

State From \ To:	1 Available	2 Preparing	3 Charging	4 SuspendedEV	5 SuspendedEVSE	6 Finishing	7 Reserved	8 Unavailable	9 Faulted
A Available		A2	A3	A4	A5		A7	A8	A9
B Preparing	B1		B3	B4	B5	B6			B9
C Charging	C1			C4	C5	C6		C8	C9
D SuspendedEV	D1		D3		D5	D6		D8	D9
E SuspendedEVSE	E1		E3			E6		E8	E9
F Finishing	F1	F2					F8	F9	
G Reserved	G1	G2					G8	G9	
H Unavailable	H1	H2		H4	H5				H9
I Faulted	I1	I2	I3	I4	I5	I6	I7	I8	

- A2 Usage is initiated (e.g. insert plug, bay occupancy detection, present idTag, push start button, receipt of a RemoteStartTransaction.req)
- A3 Can be possible in a Charge Point without an authorization means
- A4 Similar to A3 but the EV does not start charging
- A5 Similar to A3 but the EVSE does not allow charging
- A7 A Reserve Now message is received that reserves the connector
- A8 A Change Availability message is received that sets the connector to Unavailable
- A9 A fault is detected that prevents further charging operations
- B1 Intended usage is ended (e.g. plug removed, bay no longer occupied, second presentation of idTag, time out (configured by the configuration key: ConnectionTimeOut) on expected user action)
- B3 All prerequisites for charging are met and charging process starts
- B4 All prerequisites for charging are met but EV does not start charging
- B5 All prerequisites for charging are met but EVSE does not allow charging
- B6 Timed out. Usage was initiated (e.g. insert plug, bay occupancy detection), but idTag not presented within timeout.
- B9 A fault is detected that prevents further charging operations
- C1 Charging session ends while no user action is required (e.g. fixed cable was removed on EV side)
- C4 Charging stops upon EV request (e.g. S2 is opened)
- C5 Charging stops upon EVSE request (e.g. smart charging restriction, transaction is invalidated by the AuthorizationStatus in a StartTransaction.conf)
- C6 Transaction is stopped by user or a Remote Stop Transaction message and further user action is required (e.g. remove cable, leave parking bay)
- C8 Charging session ends, no user action is required and the connector is scheduled to become Unavailable
- C9 A fault is detected that prevents further charging operations



3. Earth EV App

- D1 Charging session ends while no user action is required
- D3 Charging resumes upon request of the EV (e.g. S2 is closed)
- D5 Charging is suspended by EVSE (e.g. due to a smart charging restriction)
- D6 Transaction is stopped and further user action is required
- D8 Charging session ends, no user action is required and the connector is scheduled to become Unavailable
- D9 A fault is detected that prevents further charging operations

- E1 Charging session ends while no user action is required
- E3 Charging resumes because the EVSE restriction is lifted
- E4 The EVSE restriction is lifted but the EV does not start charging
- E6 Transaction is stopped and further user action is required
- E8 Charging session ends, no user action is required and the connector is scheduled to become Unavailable
- E9 A fault is detected that prevents further charging operations

- F1 All user actions completed
- F2 User restart charging session (e.g. reconnects cable, presents idTag again), thereby creating a new Transaction
- F8 All user actions completed and the connector is scheduled to become Unavailable
- F9 A fault is detected that prevents further charging operations

- G1 Reservation expires or a Cancel Reservation message is received
- G2 Reservation identity is presented
- G8 Reservation expires or a Cancel Reservation message is received and the connector is scheduled to become Unavailable
- G9 A fault is detected that prevents further charging operations

- H1 Connector is set Available by a Change Availability message
- H2 Connector is set Available after a user had interacted with the Charge Point
- H3 Connector is set Available and no user action is required to start charging
- H4 Similar to H3 but the EV does not start charging
- H5 Similar to H3 but the EVSE does not allow charging
- H9 A fault is detected that prevents further charging operations

- I1-I8 Fault is resolved and status returns to the pre-fault state



3. Earth EV App

3.5 User Interface Design

The Earth EV app implements a professional and intuitive user interface, adhering to the following design principles:

- Clean, modern design language
- Efficient navigation system utilising a top navigation bar
- Responsive layout optimised for various device form factors

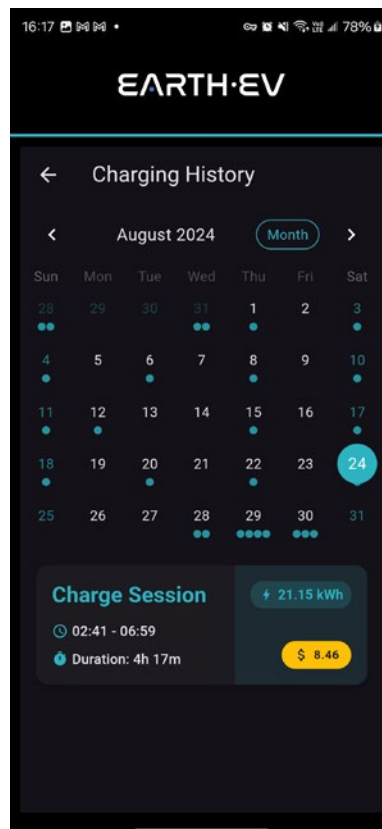

Charging History and Monitoring



4. System Capabilities

4.1 Charger Management

- **Remote Charger Activation and Deactivation:** Allows users to remotely start or stop their Earth EV chargers through the mobile application, providing convenience and control from any location.
- **Firmware Updates and Configuration Management:** Enables the remote updating of charger firmware and management of configuration settings to ensure chargers are running the latest software and are properly configured.
- **Real-time Monitoring of Charger Status and Performance:** Provides live updates on the operational status and performance metrics of chargers, allowing users to monitor their chargers' health and efficiency.
- **Bluetooth Connectivity for Local Charger Control:** Supports local control of chargers via Bluetooth, allowing users to manage their chargers even without internet connectivity.
- **Comprehensive Charger Information Display:** Displays detailed information about each charger, including type, power output specifications, and other relevant data, helping users make informed decisions.
- **Live Charging Status Monitoring:** Provides real-time updates on the charging status of connected vehicles, including current charging state and charging duration.
- **Real-time Power Output and Charging Speed Visualisation:** Visualises the power output and charging speed in real-time, allowing users to see how efficiently their chargers are operating.

4.2 User Management

- **User Registration and Profile Management:** Allows new users to register and create profiles, and existing users to manage their personal information and preferences.
- **Integration with Google Sign-In:** Provides seamless user authentication by integrating with Google Sign-In, allowing users to log in using their Google accounts.

4.3 Charging Session Management

- **Scheduling and Reservation of Charging Sessions:** Allows users to create charging schedules that define charger behaviour at designated times
- **Automated Start and Stop of Charging Sessions:** Automates the initiation and termination of charging sessions, providing a hassle-free charging experience.
- **Real-time Monitoring of Charging Progress:** Provides live updates on the progress of ongoing charging sessions, including the amount of energy delivered and the duration of the current charging session.



5. Operational Information

5.1 LED Indicator and Troubleshooting

Light Status	Description
Solid Yellow	APP Mode: not connected to EV and not connected to the back
Solid Blue	APP Mode: not connected to EV but connected to the back end, RFID or Plug and Charge; not connected to EV
Blue Flashing	Connected to EV
Blue Flashing slowly	Reservation in progress
Green streaming	Charging
Green Flashing	Charging finished
Solid Red	Unavailable
Red Flashing Fast	Firmware update: Please contact Earth-EV to get correct firmware
RED flashes 1 time	Leakage. Switch off at the distribution box. Check whether the charging connector and its cable are damaged or wet. After checking, turn the power back on. If the problem still exists, contact Earth-EV customer support
RED flashes 2 times	Over current <ul style="list-style-type: none">· Check whether the charging connector is correctly connected· Check whether the On-board Charger (OBC) is normal
RED flashes 3 times	Charging station is not grounded; input power cable needs to be checked
RED flashes 4 times	Overvoltage or undervoltage <ul style="list-style-type: none">· Check whether the input cable is properly connected· Check whether the input voltage is abnormal
RED flashes 5 times	Contactor failure or electronic lock failure <ul style="list-style-type: none">· Check whether the contactor connection is reliable· Check that the electronic lock connection is reliable If the problem still exists, contact customer support
RED flashes 6 times	CP abnormal <ul style="list-style-type: none">· Check the charging connector and charging socket of EV· Disconnect and reconnect the charging connector
RED flashes 7 times	Electronic lock fault <ul style="list-style-type: none">· Check that the electronic lock connection is reliable
RED flashes 10 times	Tamper event <ul style="list-style-type: none">· Check that the charger face cover is open
RED flashes 11 times	Energy meter communication fault. Check whether the communication cable of the charger meter is properly connected or loose. Check that the baud rate of the meter is 9600 (Optional)
RED flashes 12 times	No vehicle diode detected, confirm the presence of a diode
RED flashes 13 times	Please check whether the RS485 communication cable is connected correctly



5. Operational Information

5.2 App Troubleshooting

Common Issues and Solutions	
App Connection Issues	<ul style="list-style-type: none">· Ensure you have a stable internet connection.· Try force-closing the app and reopening it.· Uninstall and reinstall the app if the issue persists.· Check for any app updates and install them.· The app has the necessary permissions to access the internet.· Restart your device to clear any potential network issues.
Charger Communication Problems	<ul style="list-style-type: none">· Verify that the charger is powered on and connected to the internet.· For Bluetooth connections, ensure Bluetooth is enabled on your device and you're within range.· Try restarting the charger.· Check for any firmware updates for the charger.· Ensure the app has the necessary permissions to access Bluetooth and location services.· Remove and re-add the charger in the app.· Check if other devices can connect to the charger to rule out hardware issues.
Charging Session Not Starting	<ul style="list-style-type: none">· Ensure the vehicle is properly connected to the charger.· Check for any error messages in the app.· Ensure the app is synchronised with the charger by refreshing the connection.· Check the app's scheduling settings to ensure there are no conflicts.
Incorrect Energy Readings	<ul style="list-style-type: none">· Ensure the charger firmware is up to date.· Compare readings with your vehicle's onboard systems.· Contact support if discrepancies persist, as calibration may be required.· Check the app for any software updates that might address known issues.· Verify that the charger is properly configured in the app settings.· Reset the charger to factory settings and reconfigure it.



5. Operational Information

5.2 App Troubleshooting

Common Issues and Solutions	
App Crashes or Freezes	<ul style="list-style-type: none">· Ensure your device meets the minimum system requirements for the app.· Clear the app's cache and data from your device settings.· Uninstall and reinstall the app.· Check for any available updates for your device's operating system.· Disable any battery optimisation settings for the app.· Contact support if the issue persists, providing details about your device and app version.
OCR-based Serial Number Scanning Issues	<ul style="list-style-type: none">· Ensure the camera has the necessary permissions to access the app.· Make sure the camera lens is clean and unobstructed.· Ensure there is adequate lighting when scanning the serial number.· Try adjusting the distance between the camera and the serial number.· Restart the app and try scanning again.· Check for any app updates that might improve OCR functionality.
Cloud Synchronisation Issues	<ul style="list-style-type: none">· Ensure your device is connected to the internet.· Ensure the app is up to date.· Try logging out and logging back into the app.· Contact support if synchronisation issues persist.



5. Operational Information

5.2 App Troubleshooting

Wi-Fi Connection	<ul style="list-style-type: none">· If there is no connection, it will say wifi disconnected in the Earth EV Apps 'bluetooth connection, located under network parameters.
Wi-Fi Strength	<ul style="list-style-type: none">· Check your Wi-Fi strength by turning off your mobile phones data next to your charger and see if you can see the Wi-Fi signal. If it doesn't have a decent signal you may need to install a booster near your Earth-EV charger.
Wi-Fi Router Settings	<ul style="list-style-type: none">· Check your Wi-Fi router has 2.4GHz mode switched on, normally this is on the back of your Wi-Fi router. However, you can check this by using your phone or computer· iPhone - Go to Wi-Fi settings: Open the Settings app and select 'Wi-Fi'. Access network details: Tap on the blue information icon (i) next to the network you're connected to. View the frequency band: Under the 'Network Details' section, you'll find the frequency band labelled either as 2.4GHz or 5GHz.· Android - Use your Android phone to connect to the Wi-Fi network. Go to Settings > Wi-Fi > Select the connected network to see the Wi-Fi details. Note: Different Android phones might have different settings. Read the frequency band setting.· Computer - In Windows 10 (once you connect) you just go to Settings / Network & Internet / click on the SSID name and scroll down to Properties. It tells you the band, protocol, channel, security type, and all that good stuff.



5. Operational Information

5.3 Maintenance

Regular maintenance of EV chargers by both users and electrical professionals is essential for ensuring their long-term stable operation and safety. This document outlines maintenance procedures for our EV chargers (7kW and 22kW), detailing checks for both electrical professionals and users.

Maintenance Schedule Regular maintenance intervals are crucial, typically scheduled daily for user checks and annually for electrical professional inspections.

Routine Checks for Users (daily)

- | | |
|---|---|
| ✓ | Visually inspect the charger and its surroundings for signs of damage, corrosion, or hazards. |
| ✓ | Check the status indicators for normal operation and refer to the user manual for interpretation. |
| ✓ | Ensure the charging cable is undamaged and correctly stored. |
| ✓ | Verify the secure connection of the charger to the power supply. |
| ✓ | Avoid placing flammable materials or objects near the charging station. |
| ✓ | Report any abnormalities or safety concerns to appointed maintenance personnel immediately. |

Maintenance Procedures for Electrical Professionals (Annually): Electrical professionals should conduct comprehensive inspections to ensure proper functioning and safety.

Professional Maintenance:

- | | |
|---|---|
| ✓ | Conduct thorough functionality and safety inspections to ensure the charger's optimum performance and electrical safety. |
| ✓ | Inspect electrical connections, including terminals, wiring, and contactors, for signs of wear or damage. |
| ✓ | Assess the integrity of internal components, including RCDs, fuses, relays, and contactors, and replace them if necessary. |
| ✓ | Verify the charger's grounding system for proper grounding and electrical safety. |
| ✓ | Test the charger's insulation resistance to identify any insulation breakdown or leakage. |
| ✓ | Perform thermal inspections using an infrared camera to detect hotspots indicative of potential failure. |
| ✓ | Review and update the charger's software/firmware to the latest version if applicable. |
| ✓ | Calibrate the charger's metering and billing system for accurate energy consumption measurement (coming soon in EARTH-EV APP). |
| ✓ | Conduct grid voltage and frequency tests to ensure the charger operates within specified parameters. |

By adhering to the outlined maintenance procedures, potential issues can be identified and addressed promptly, contributing to the efficiency and reliability of EV charging infrastructure.



5. Operational Information

5.4 Product Warranty

The warranty provided herein applies solely to the designated Earth EV's Electric Vehicle (EV) charging devices and software as a service solutions ("the product").

1. Warranty Period

The warranty period for the Earth EV Electric Vehicle (EV) charger is 5 years from the date of manufacture. This warranty covers the charger itself and does not extend to any associated costs, including but not limited to travel, labor, consumables, or any other expenses incurred during the repair or replacement process. Earth EV will, at its discretion, repair or replace the charger if a failure or damage is determined by the company's technical personnel to have occurred under normal usage conditions.

2. Exclusions from Warranty

Replacement or repairs fees will be charged for the following situations, even during the warranty period:

- a) Equipment failure due to non-compliance with the installation and operation manual.
- b) Equipment damage resulting from fire, flood, abnormal voltage, or similar external factors.
- c) Equipment damage due to usage for purposes not intended or specified.
- d) Equipment damage caused by the ingress of any foreign matter.
- e) Equipment damage attributed to other human-induced external factors.

3. Service Fees

The warranty covers only repair or replacement of the product itself and does not include any provision for labor, travel, or incidental expenses.

4. Obligations

It is imperative to utilise the Earth EV APP so we can assist with the monitoring and health of the charger. Present this warranty document, along with proof of purchase, and present it to authorized maintenance personnel during any warranty claims or repair services.



5. Operational Information

5. Limitation of Liability

The limitation of liability clause states that Earth EV shall not be held responsible for any special, indirect, consequential, or economic loss or damage suffered by the consumer or any other person because of any act or omission by Earth EV. This includes but is not limited to the loss of profits, loss of revenue, loss of business opportunities, or any other form of financial or economic loss.

This clause serves to protect Earth EV from being held accountable for damages beyond the direct cost of repairing or replacing the product covered under the warranty. It acknowledges that while Earth EV endeavors to provide reliable products and services, it cannot be held responsible for unforeseen or indirect consequences that may arise from product use or failure.

It is important for consumers to understand that while Earth EV stands behind its products and warranties, there are limitations to the extent of liability, especially concerning indirect or consequential damages.

This limited warranty agreement is subject to the terms and conditions outlined herein and does not affect the consumer's statutory rights under applicable laws. This warranty is offered by Diatom Australia Pty LTD. For any inquiries or assistance, please reach out to your designated agent for warranty-related matters.



6. Contacting Support

If you encounter issues that cannot be resolved using the troubleshooting steps outlined in this manual, please contact our support team:

- Email: **contact@earthev.com.au**
- Phone: **1300 345 624**
- Homepage: **www.earthev.com.au**

When contacting support, please provide:

- Your account email address
- Device model and operating system version
- App version
- Charger serial number (if applicable)
- Detailed description of the issue, including any error messages
- Steps to reproduce the issue, if possible.



Earth EV Australia

Phone: 1300 345 624

Email: contact@earthev.com.au

BY  **diatom**